

	"A"	"B"	"C"
800W	1110	870	900
900W	1210	970	1000
1100W	1410	1170	1200

A - PRODUCT WIDTH  
 B - USABLE PLATFORM WIDTH  
 C - GATE POST WIDTH

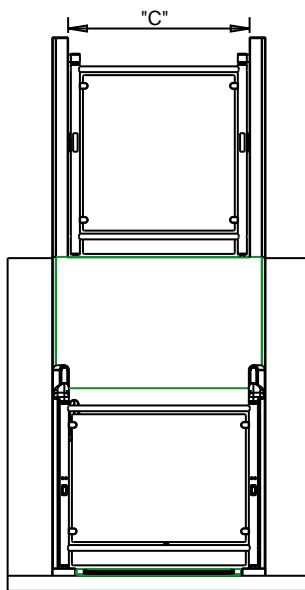
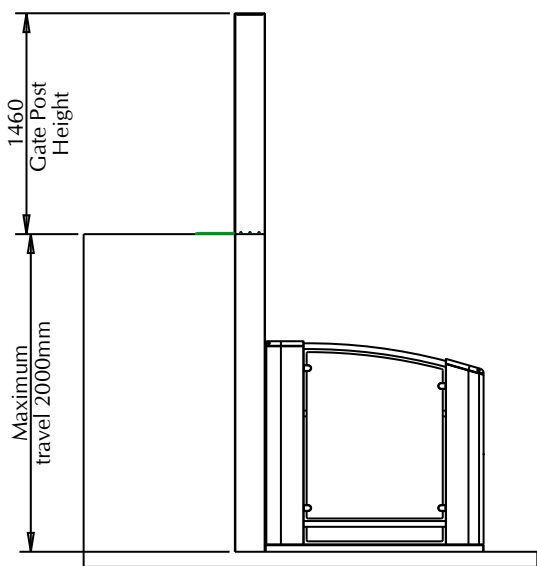

### Standard Specification:

Application range: People with impaired mobility and Wheelchair users, Internal & External locations  
 Maximum Safe working load: 500kg  
 Maximum travel: 2000mm  
 Rated speed: 0,1 meters per second  
 Power supply electrical requirements: 220/240V 13A single phase (max), Dedicated RCD protected supply  
 Low voltage control system: 24VDC  
 Operating temperature range -10 to +40 Drive:  
 Direct acting hydraulic  
 Power Pack: Integral to rail structure,  
 Standard Compliance : BS8300, ISO9386-1 Machinery Directive 98/37/EC

OPTIONS:  
 Powered Upper and Lower Level Gates

